

# Bellows-Sealed Valves

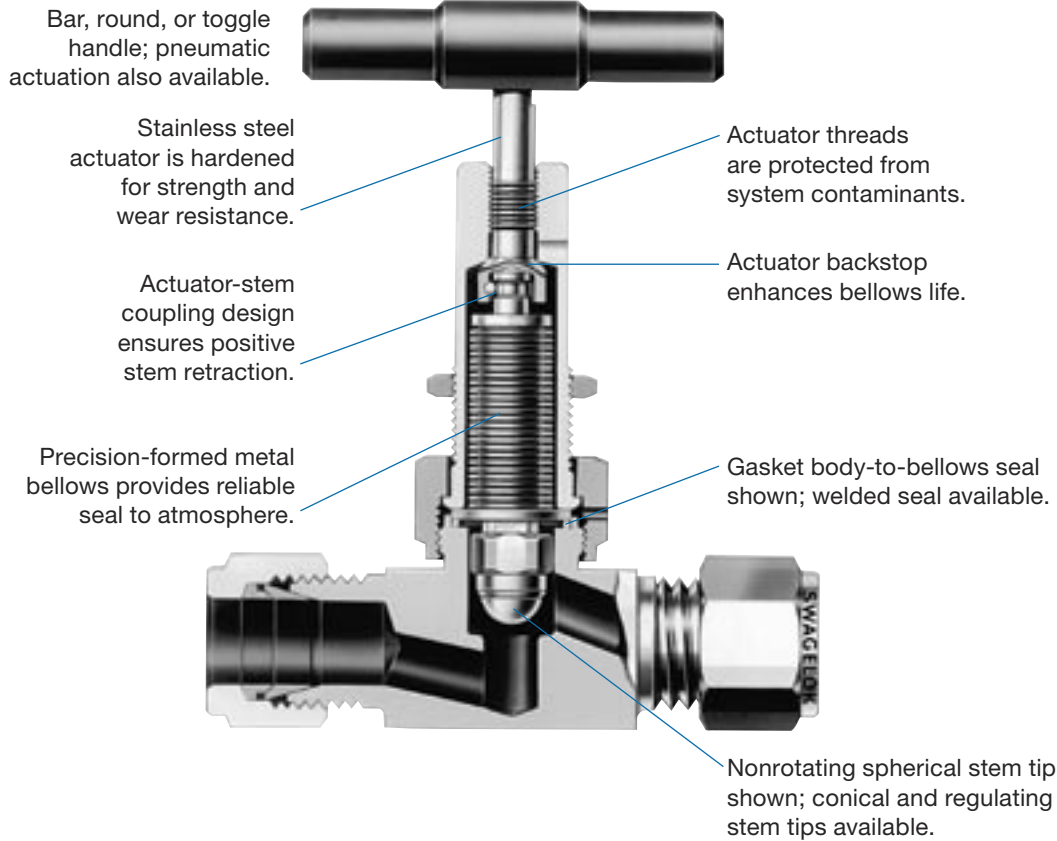

## B Series

- Working pressures up to 1000 psig (68.9 bar)
- Temperatures up to 900°F (482°C)
- 1/4, 3/8, 1/2, and 3/4 in.; 6, 10, and 12 mm end connections
- Brass, stainless steel, and alloy 400 materials



## Features

Swagelok® B series bellows-sealed valves are available in a variety of models for system versatility.

- Gasketed or welded body-to-bellows seals
- Stem tips for shutoff or regulating service
- Flow coefficients ( $C_v$ ) from 0.12 to 1.2
- Variety of end connections:
  - Swagelok tube fittings—1/4 to 1/2 in. and 6 to 12 mm
  - Tube socket weld ends—1/4 to 1/2 in.
  - Tube butt weld ends—3/8 to 3/4 in.
  - Female VCR® face seal fittings—1/4 and 1/2 in.
  - Integral male VCR face seal fittings—1/4 and 1/2 in.
- Panel and bottom mounting

## Technical Data

Body-to-Bellows Seal	Valve Body Materials	Stem Tip	Handle Type	$C_v$ <sup>①</sup>	Internal Volume <sup>①</sup> in. <sup>3</sup> (cm <sup>3</sup> )	Series <sup>②</sup>
Gasket	Brass, 316 SS, alloy 400	Metal (regulating)	Round	0.20	0.16 (2.6)	4BRG
				0.36	0.10 (1.6)	4BK
		PCTFE (conical)	Bar	1.0	0.24 (3.9)	6BK
				1.2	0.26 (4.3)	8BK
		Metal (spherical in brass and 316 SS; conical in alloy 400)	Round	0.36	0.10 (1.6)	4BG
			Bar	1.0	0.24 (3.9)	6BG
1.2	0.26 (4.3)	8BG				
Weld	316 SS, alloy 400	Metal (regulating)	Round	0.12	0.16 (2.6)	4BRW
				0.33	0.10 (1.6)	4BW
		Metal (spherical in 316 SS; conical in alloy 400)	Bar	1.0	0.24 (3.9)	6BW
				1.1	0.26 (4.3)	8BW

① Determined using valves with Swagelok tube fitting end connections.

② **R** designates regulating stem tip; **G** designates gasket body-to-bellows seal; **K** designates PCTFE stem tip (conical); **T** designates toggle handle; **W** designates welded body-to-bellows seal.

### Materials of Construction

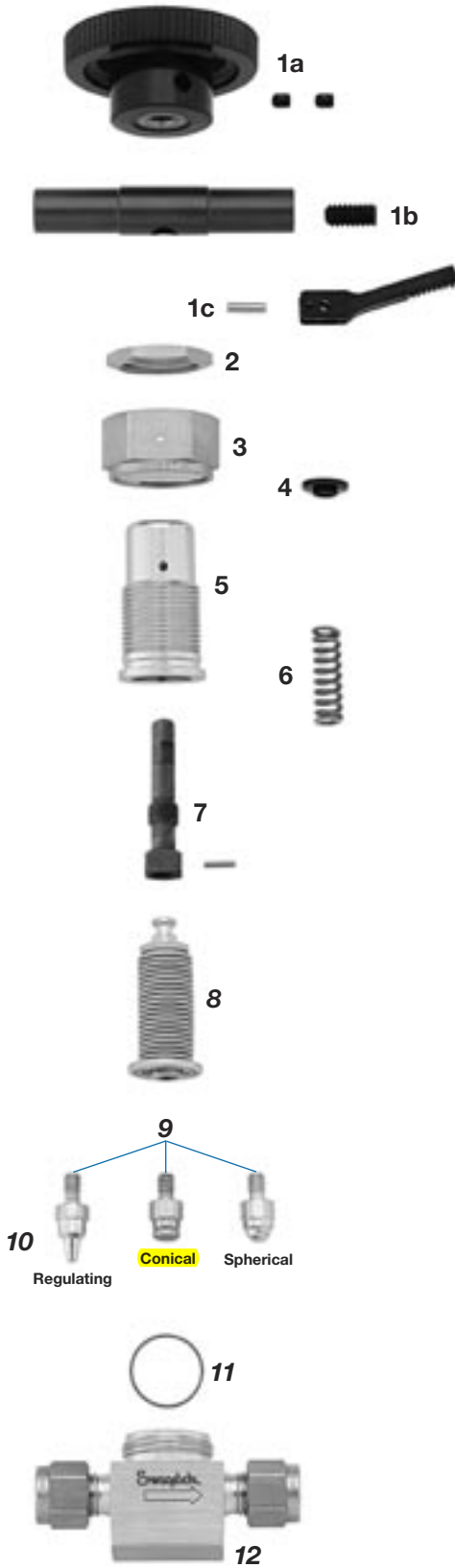

Component	Series	Valve Body Materials		
		Brass <sup>①</sup>	316 SS	Alloy 400
Material Grade/ASTM Specification				
1a Handle Set screws	4BG, 4BRG, 4BK, 4BW, 4BRW	Green phenolic		
		Alloy steel/ANSI 18.3		
1b Handle Set screw	6BG, 8BG, 6BK, 8BK, 6BW, 8BW	Green anodized aluminum 2024-T4/B211		
		Alloy steel/ANSI 18.3		
1c Handle Handle pin	4BKT	Black nylon		
		302 SS		
2 Panel mount nut	All	Brass/B16	316 SS/B783	
3 Bonnet nut	All except 4BKT	Brass/B16	Silver-plated 316 SS/A479	
	4BKT	Silver-plated brass/B16		
4 Gland	4BKT	Nylon		
5 Bonnet	All	Brass/B16	316 SS/A479	
6 Spring	4BKT	S17700/AMS 5678		
7 Actuator Actuator pin	All except 4BKT	416 SS/A582		
	4BKT	303 SS/A582		
8 Stem Bellows Weld ring	All	316 SS/A479	Alloy 400/B164	
	All	321 SS/A269	Alloy 400/B165	
	All	316 SS/A479	Alloy 400/B164	
9 Stem adapter	All	316 SS/A479	Alloy 400/B164	
10 Stem tip	4BRG, 4BRW	316 SS/A479 (regulating)	Alloy K-500/AMS 4676 (regulating)	
	4BK, 6BK, 8BK, 4BKT	PTCFE/D1430 (conical)		
	4BG, 6BG, 8BG, 4BW, 6BW, 8BW	Cobalt-based alloy (spherical)	Alloy K-500/AMS 4676 (conical)	
11 Gasket	4BG, 6BG, 8BG, 4BRG	Silver-plated 316 SS/A580	Silver-plated alloy 400/AMS 4730	
	4BK, 6BK, 8BK, 4BKT	PTCFE-coated 316 SS/A580	PTCFE-coated alloy 400/AMS 4730	
12 Body Wetted lubricant	All	Brass/B16	316 SS/A479	Alloy 400/B164
	4BG, 6BG, 8BG, 4BW, 6BW, 8BW	Fluorinated-based (spherical stem tip)		—
Nonwetted lubricant	All	Molybdenum disulfide-based		

Wetted components listed in *italics*.

Additional stem tip options available. See **Options**, page 9.

① Valves with welded body-to-bellows seal (4BRW, 4BW, 6BW, 8BW) not available in brass.

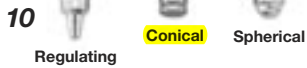

#### Gasket Seal

##### BG Series

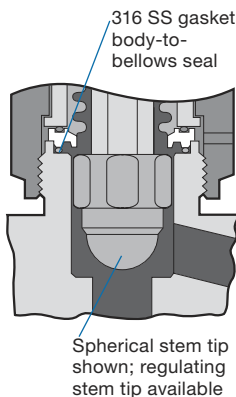

##### BK Series

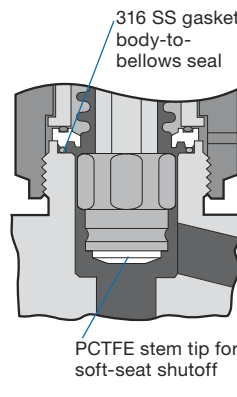

#### Welded Seal

##### BW Series

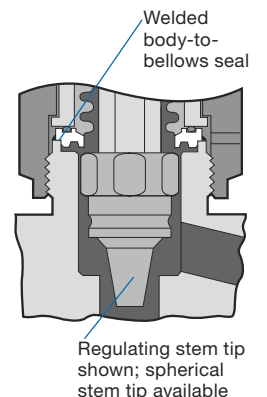

## Pressure-Temperature Ratings

### BG, BRG, BW, and BRW Series

**G** designates gasket body-to-bellows seal; **R** designates regulating stem tip; **W** designates welded body-to-bellows seal.

BRW series valves are not recommended for shutoff above 600°F (315°C).

Ratings apply to manual valves and to valves with 5 series pneumatic actuators.

Material	Brass <sup>①</sup>		316 SS		Alloy 400
Series	BG	BRG	BW	BRW, BG, BRG	BW, BRW, BG, BRG
Temperature, °F (°C)	Working Pressure, psig (bar)				
-20 (-28) to 100 (37)	1000 (68.9)	450 (31.0)	1000 (68.9)	1000 (68.9)	700 (48.2)
200 (93)	710 (48.9)	350 (24.1)	830 (57.1)	830 (57.1)	610 (42.0)
300 (148)	430 (29.6)	250 (17.2)	660 (45.4)	660 (45.4)	530 (36.5)
400 (204)	150 (10.3)	150 (10.3)	500 (34.4)	500 (34.4)	450 (31.0)
500 (260)	—	—	450 (31.0)	450 (31.0)	375 (25.8)
600 (315)	—	—	400 (27.5)	400 (27.5)	—
650 (343)	—	—	360 (24.8)	—	—
700 (371)	—	—	330 (22.7)	—	—
750 (398)	—	—	300 (20.6)	—	—
800 (426)	—	—	260 (17.9)	—	—
850 (454)	—	—	230 (15.8)	—	—
900 (482)	—	—	200 (13.7)	—	—

For more information about pressure ratings of valves with tube fitting end connections, see Swagelok *Tubing Data*, MS-01-107.

① Due to the brass bonnet threads, cycle life of brass valves may be reduced when operated frequently at pressures above 450 psig (31.0 bar). Brass valves only available with manual or 1 series pneumatic actuators.

## Handle Temperature Gradient

### 316 SS Valves

When Valve Seat Is	Valve Handle Is
600°F (315°C)	195°F (90°C)
900°F (482°C)	275°F (135°C)

## BK Series

**K** designates PCTFE stem tip.

Ratings apply to manual valves and to valves with **1 series** or 5 series pneumatic actuators.

Actuation Mode	Manual and 5 Series Pneumatic Actuators		1 Series Pneumatic Actuators			
			Normally Closed	Normally Open	Double Acting	
Material	Brass <sup>①</sup>	316 SS	Alloy 400	Brass, <sup>①</sup> 316 SS, Alloy 400		
Temperature, °F (°C)	Working Pressure, psig (bar)					
-20 (-28) to 100 (37)	1000 (68.9)	1000 (68.9)	700 (48.2)	125 (8.6)	500 (34.4)	700 (48.2)
200 (93)	710 (48.9)	830 (57.1)	610 (42.0)	125 (8.6)	500 (34.4)	700 (48.2) <sup>②</sup>

For more information about pressure ratings of valves with tube fitting end connections, see Swagelok *Tubing Data*, MS-01-107.

① Due to the brass bonnet threads, cycle life of brass valves may be reduced when operated frequently at pressures above 450 psig (31.0 bar). Brass valves only available with manual or 1 series pneumatic actuators.

② 610 psig (42.0 bar) for alloy 400 valves with double-acting pneumatic actuators.

## BKT Series

**K** designates PCTFE stem tip; **T** designates toggle handle.

100 psig (6.8 bar) at -20 to 200°F (-28 to 93°C).

### Flow Data at 70°F (20°C)

**R** designates regulating stem tip; **G** designates gasket body-to-bellows seal; **W** designates welded body-to-bellows seal; **K** designates PCTFE stem tip; **T** designates toggle handle.

- 4BRG, 4BRW
- 4BG, 4BW, 4BK
- 8BG, 8BW, 8BK
- 4BKT
- 6BG, 6BW, 6BK

#### Air

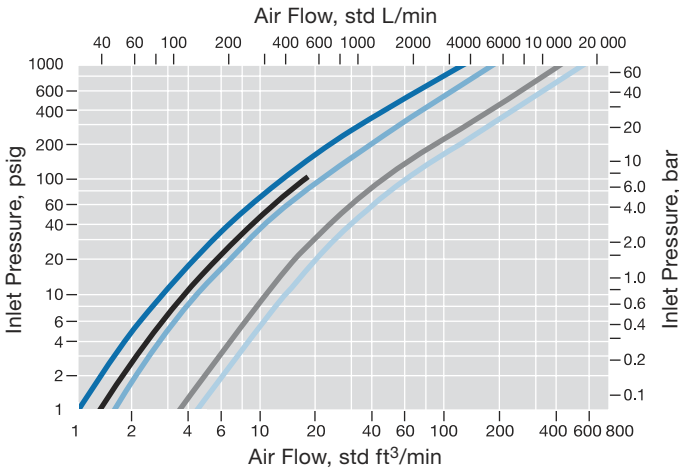

#### Water

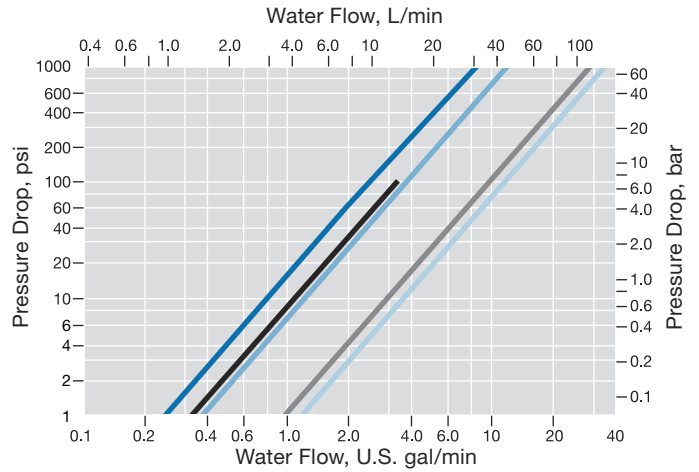

### Flow Coefficient at Turns Open

Maximum number of turns open for valves with welded body-to-bellows seal:

- 4BRW, 4BW—1.5 turns
- 6BW, 8BW—3 turns

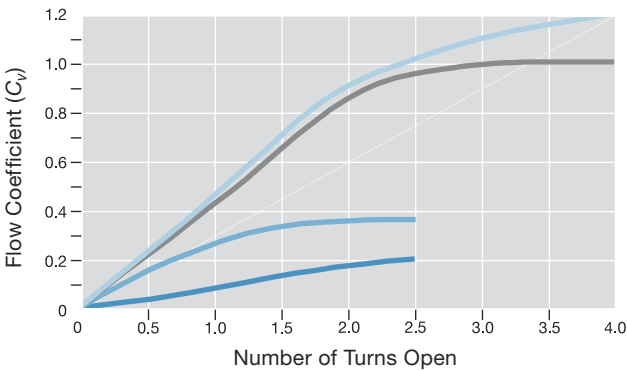

### Testing

Every B series valve is factory tested with helium for 5 s to a maximum leak rate of  $4 \times 10^{-9}$  std cm<sup>3</sup>/s at the seat, envelope, and all seals.

### Cleaning and Packaging

Swagelok B series valves with VCR end connections and all BK series valves are processed in accordance with Swagelok *Special Cleaning and Packaging (SC-11)*, MS-06-63, to ensure compliance with product cleanliness requirements stated in ASTM G93 Level C.

Swagelok B series valves with other end connections are processed in accordance with Swagelok standard cleaning and packaging specification (SC-10), MS-06-62; special cleaning and packaging are available as an option.

## Ordering Information and Dimensions

### Stainless Steel Valves

Select an ordering number.

### Brass and Alloy 400 Valves

Replace **SS** with **B** for brass or **M** for alloy 400.

Example: **B-4BG**

Dimensions, in inches (millimeters), are for reference only and are subject to change.

End Connections		Ordering Number	Series	Dimensions, in. (mm)										
Type	Size			Orifice	A	B	C	D	E	F	G	H	J	K
Fractional Swagelok tube fitting	1/4 in.	SS-4BG	4BG	0.16 (4.1)	3.64 (92.5)	0.56 (14.2)	1.45 (36.8)	1.00 (25.4)	1.88 (47.8)	2.46 (62.5)	1.06 (26.9)	1.00 (25.4)	—	—
		SS-4BK	4BK											
		SS-4BW	4BW											
		SS-4BRG	4BRG											
		SS-4BRW	4BRW											
	SS-4BKT	4BKT	4.18 (106)											
	3/8 in.	SS-6BG	6BG	0.26 (6.6) port	4.19 (106)	0.50 (12.7)	1.57 (39.9)	1.13 (28.7)	2.50 (63.5)	3.09 (78.5)	1.57 (39.9)	1.13 (28.7)	—	—
		SS-6BK	6BK											
		SS-6BW	6BW											
	1/2 in.	SS-8BG	8BG	0.30 (7.6)	4.19 (106)	0.50 (12.7)	1.57 (39.9)	1.13 (28.7)	2.50 (63.5)	3.30 (83.8)	1.57 (39.9)	1.13 (28.7)	—	—
		SS-8BK	8BK											
		SS-8BW	8BW											
Metric Swagelok tube fitting	6 mm	SS-6BG-MM	4BG	0.16 (4.1)	3.64 (92.5)	0.56 (14.2)	1.45 (36.8)	1.00 (25.4)	1.88 (47.8)	2.46 (62.5)	1.06 (26.9)	1.00 (25.4)	—	—
		SS-6BK-MM	4BK											
		SS-6BW-MM	4BW											
		SS-6BKT-MM	4BKT		4.50 (114)									
	10 mm	SS-10BG-MM	6BG	0.28 (7.1) port	4.19 (106)	0.50 (12.7)	1.57 (39.9)	1.13 (28.7)	2.50 (63.5)	3.11 (79.0)	1.57 (39.9)	1.13 (28.7)	—	—
		SS-10BK-MM	6BK											
		SS-10BW-MM	6BW											
	12 mm	SS-12BG-MM	8BG	0.30 (7.6)	4.19 (106)	0.50 (12.7)	1.57 (39.9)	1.13 (28.7)	2.50 (63.5)	3.30 (83.8)	1.57 (39.9)	1.13 (28.7)	—	—
		SS-12BK-MM	8BK											
SS-12BW-MM		8BW												
Tube socket weld and tube butt weld	1/4 and 3/8 in.	SS-4BG-TW	4BG	0.16 (4.1)	3.64 (92.5)	0.56 (14.2)	1.45 (36.8)	1.00 (25.4)	1.88 (47.8)	1.68 (42.7)	1.00 (25.4)	0.38 (9.7)	0.25 (6.4)	
		SS-4BK-TW	4BK											
		SS-4BW-TW	4BW											
		SS-4BRW-TW	4BRW		4.18 (106)									
	3/8 and 1/2 in.	SS-6BG-TW	6BG	0.28 (7.1) port	4.19 (106)	0.50 (12.7)	1.57 (39.9)	1.13 (28.7)	2.50 (63.5)	2.27 (57.7)	1.52 (38.6)	1.13 (28.7)	0.50 (12.7)	0.38 (9.7)
		SS-6BK-TW	6BK											
		SS-6BW-TW	6BW											
	1/2 and 3/4 in.	SS-8BG-TW	8BG	0.30 (7.6)	4.19 (106)	0.50 (12.7)	1.57 (39.9)	1.13 (28.7)	2.50 (63.5)	2.27 (57.7)	1.52 (38.6)	1.13 (28.7)	0.75 (19.1)	0.50 (12.7)
		SS-8BK-TW	8BK											
		SS-8BW-TW	8BW											
	Butt welded female VCR fitting	1/4 in.	SS-4BG-V51	4BG	0.16 (4.1)	3.64 (92.5)	0.56 (14.2)	1.45 (36.8)	1.00 (25.4)	1.88 (47.8)	2.76 (70.1)	1.00 (25.4)	—	—
			SS-4BK-V51	4BK										
SS-4BW-V51			4BW											
1/2 in.		SS-6BG-V19	6BG	0.30 (7.6)	4.19 (106)	0.50 (12.7)	1.57 (39.9)	1.13 (28.7)	2.50 (63.5)	5.19 (132)	1.52 (38.6)	1.13 (28.7)	—	—
		SS-6BK-V19	6BK											
		SS-6BW-V19	6BW											
		SS-8BK-V19	8BK							4.49 (114)				
		SS-8BG-V47	8BG											
		SS-8BK-V47	8BK							3.09 (78.5)	1.25 (31.8)			
		SS-8BW-V47	8BW											
Integral male VCR fitting	1/4 in.	SS-4BK-VCR	4BK	0.16 (4.1)	3.64 (92.5)	0.44 (11.2)	1.45 (36.8)	1.00 (25.4)	1.88 (47.8)	2.24 (56.9)	1.00 (25.4)	—	—	
	1/2 in.	SS-8BG-VCR SS-8BK-VCR	8BK	0.29 (7.4) port	4.19 (106)	0.46 (11.7)	1.57 (39.9)	1.13 (28.7)	2.50 (63.5)	3.00 (76.2)	1.52 (38.6)			1.13 (28.7)

Dimensions shown with Swagelok tube fitting nuts finger-tight.

**J** = tube butt weld diameter; **K** = tube socket weld diameter.

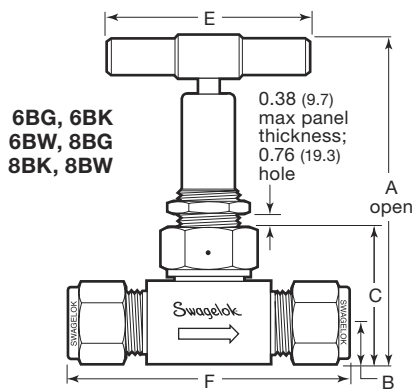
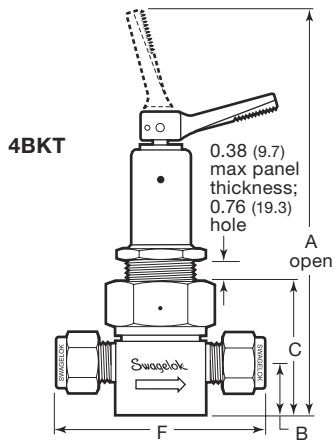
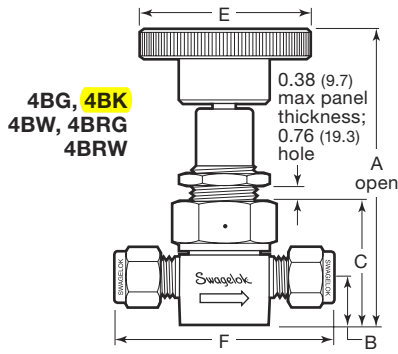

Tube socket weld and tube butt weld ends

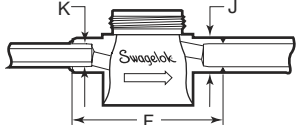

Butt welded female VCR fitting ends

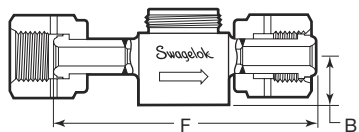

Bottom

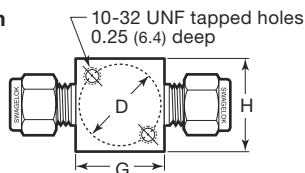

## Pneumatic Actuators



1 Series



5 Series

### Features

- Reliable piston design for enhanced cycle life
- Low actuation pressure

### Actuator Series

- 1 series actuator for BK series valves with brass, stainless steel, and alloy 400 bodies
- 5 series actuator for BG, BK, and BW series valves with stainless steel and alloy 400 bodies—not for valves with brass bodies. See the *Swagelok Pneumatic Actuators for B and U Series Bellows Valves* catalog, MS-02-09, for more information.

### Actuation Modes

**Normally closed**—air opens, spring closes

**Normally open**—air closes, spring opens

**Double acting**—air opens and closes

### Materials of Construction

Component	Actuator Series	
	1	5
Housing	Aluminum	Cast aluminum
External hardware	Stainless steel	
O-rings	Fluorocarbon FKM	Buna N

### Technical Data

Valve Series	Valve C <sub>v</sub> <sup>①</sup>	Actuator Series	Pressure Rating psig (bar)	Temperature Rating °F (°C)	Air Displacement in. <sup>3</sup> (cm <sup>3</sup> )	Weight lb (kg)
4BK	0.30	1	40 to 150 (2.7 to 10.3)	-10 to 300 (-23 to 148)	0.068 (1.11)	N/A
6BK	0.86					
8BK	0.96					
4BK, 4BG	0.36	5	50 to 150 (3.4 to 10.3)	-10 to 300 (-23 to 148)	0.83 (13.6)	C—6.7 (3.0) O—4.6 (2.1) D—4.5 (2.0)
4BW	0.33					
6BK, 6BG, 6BW	1.0					
8BK, 8BG	1.2					
8BW	1.1					

① Determined using valves with Swagelok tube fitting end connections.

## Ordering Information and Dimensions

### Actuators with Stainless Steel Valves

Add an actuator series designator, then an actuation mode designator to the valve ordering number.

Actuator Series	Designator	Actuation Mode	Designator
1	-1	Normally closed	C
		Normally open	O
5	-5	Double acting	D

Example: SS-4BG-5C

### Actuators with Alloy 400 or Brass Valves

Replace **SS** with **M** for alloy 400 or **B** for brass.

Example: M-4BG-5C

5 series actuators cannot be used with brass valves.

### 1 Series Actuator

Dimensions, in inches (millimeters), are for reference only and are subject to change.

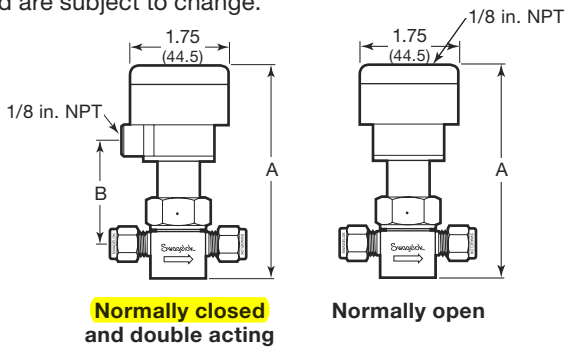

### 5 Series Actuator

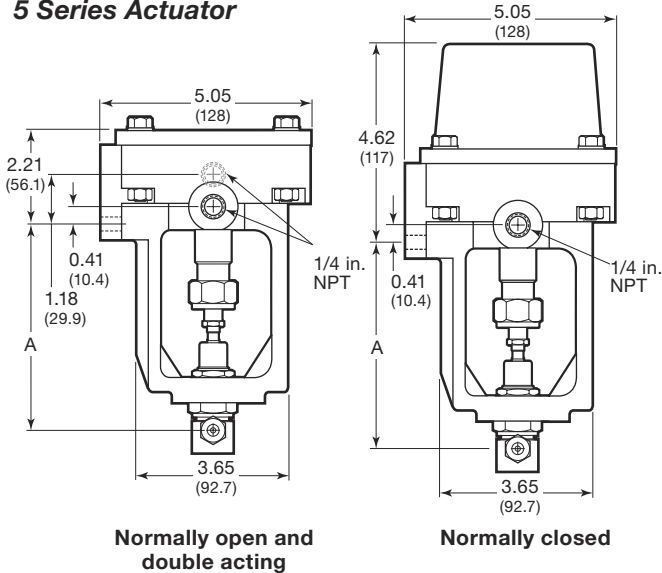

## Pneumatic Actuator Performance

### 1 Series Normally Closed and Double Acting Actuator

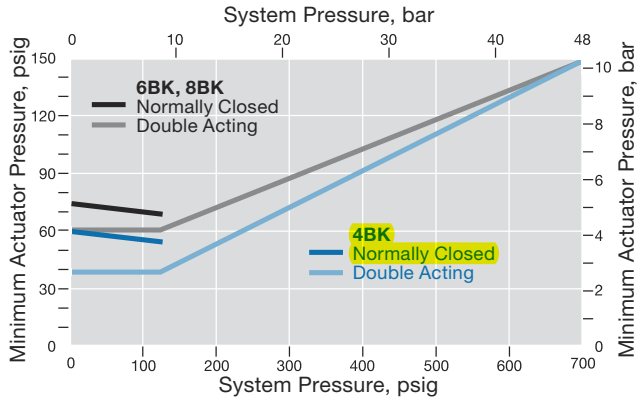

### 1 Series Normally Open Actuator

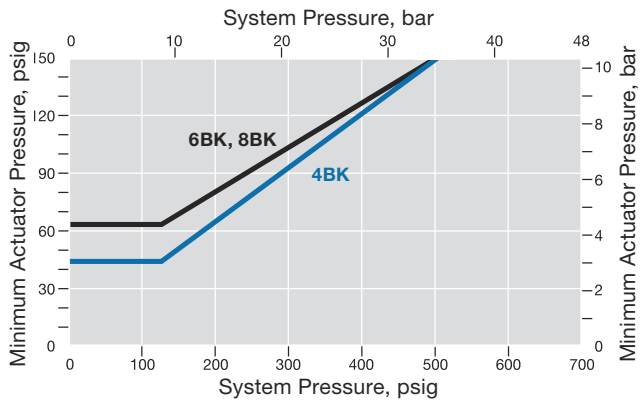

### 5 Series Actuator

The minimum actuation pressure for normally closed, normally open, and double-acting actuators is 50 psig (3.5 bar).

Valve Series	Actuator Series	Dimensions, in. (mm)	
		A	B
4BK	1	3.65 (92.7)	1.72 (43.7)
6BK, 8BK		3.76 (95.5)	1.90 (48.3)
4BK, 4BG, 4BW	5	4.87 (124)	—
6BK, 6BG, 6BW, 8BK, 8BG, 8BW		5.05 (128)	—

## Options and Accessories

### Special Cleaning and Packaging (SC-11)

Swagelok B series valves with VCR end connections and all BK series valves are processed in accordance with Swagelok *Special Cleaning and Packaging (SC-11)*, MS-06-63, to ensure compliance with product cleanliness requirements stated in ASTM G93 Level C.

To order special cleaning and packaging for B series valves with other end connections, add **-SC11** to the valve ordering number.

Example: SS-4BG-**SC11**

### BG, BK, and BW Series

#### Vacuum Stem Tip/Adapter

The vacuum stem tip/adapter helps eliminate gas pockets or trapped volumes. Features include:

- slotted adapter threads
- vented adapter cavity
- copper stem tip on BG and BW series
- PCTFE stem tip on BK series
- pressure rating equal to that of the standard valve
- temperature rating of 200°F (93°C) for BK series
- temperature rating of 400°F (204°C) for BG and BW series.

To order, add an adapter designator to the valve ordering number.

Valve Series	Vacuum Stem Tip/Adapter Designator
BG, BW	-VD
BK	-VA

Example: B-4BG-**VD**

### BG and BK Series

#### Polyimide Stem Tip

- provides soft-seat shutoff for temperatures up to 400°F (204°C) or where PCTFE is not compatible with the system fluid
- is available in manually or pneumatically actuated BG and BK series valves
- is rated to the same pressure as the standard valve.

To order, add **-VP** to the valve ordering number.

Example: SS-4BG-**VP**

#### Copper Stem Tip

- provides metal soft-seat shutoff for temperatures up to 400°F (204°C) or where PCTFE is not compatible with the system fluid
- is available in manually or pneumatically actuated BG and BK series valves
- is rated to the same pressure as the standard valve.

To order, add **-CU** to the valve ordering number.

Example: SS-4BG-**CU**



### 4BKT Series

#### Colored Toggle Handles

Black handles are standard for toggle-operated 4BKT series valves. For other colors, add a handle color designator to the valve ordering number.

Example: SS-4BKT-**BL**

Handle Color	Designator
Blue	-BL
Green	-GR
Orange	-OG
Red	-RD
White	-WH
Yellow	-YW

### BK Series

#### Indicator Switch

- Transmits a signal to an electrical device indicating either the open or closed position of a pneumatically actuated valve.
- Features single-pole, single-throw switch rated at 1/2 A for 115 V (ac) resistivity.
- Includes a 24 in. (61 cm) wire lead with an inline clip.
- Is available assembled on any normally closed BK series valve with a 1 series pneumatic actuator or for field assembly.



#### Factory-Assembled Indicator Switches

To order a valve with an indicator switch, add **M** for a normally open switch or **M-2** for a normally closed switch to the valve ordering number.

Examples: SS-4BK-1**CM**  
SS-4BK-1**CM-2**

#### Indicator Switch Kits

To order a kit for an existing valve, use ordering number **MS-ISK-BK-1CM** for a normally open switch or **MS-ISK-BK-1CM-2** for a normally closed switch.

### Maintenance Kits

Stem tip/adapter kits, bellows kits, and gasket kits are available for BG, BRG, BK, and BKT series valves. See the Swagelok *Bellows-Sealed Valve Maintenance Kits* catalog, MS-02-66.

### Oxygen Service Hazards

For more information about hazards and risks of oxygen-enriched systems, see the Swagelok *Oxygen System Safety* technical report, MS-06-13.

**Safe Product Selection**

**When selecting a product, the total system design must be considered to ensure safe, trouble-free performance. Function, material compatibility, adequate ratings, proper installation, operation, and maintenance are the responsibilities of the system designer and user.**

**Caution: Do not mix or interchange parts with those of other manufacturers.**

**Warranty Information**

Swagelok products are backed by The Swagelok Limited Lifetime Warranty. For a copy, visit [swagelok.com](http://swagelok.com) or contact your authorized Swagelok representative.

Swagelok, VCR—TM Swagelok Company  
© 2002, 2003, 2005 Swagelok Company  
Printed in U.S.A., MI  
September 2005, R7  
MS-01-22